

mino FMeter-G431

Reciprocal frequency counter with 8-11 digits resolution

This frequency counter is suitable for measuring periodic signals, whereby the reciprocal measuring method enables the highest resolution with short measuring times. The basic resolution is 8 digits / s. With a higher input frequency, each individual interval is recorded up to 200 kHz and a significantly higher resolution of 10 digits / s is achieved through statistical evaluation. Extending the measurement interval to 10 s further increases the resolution.

In addition to the main input F1, which covers the frequency range from approx. 0.1 Hz – 150 MHz, there is an auxiliary input F2 with a reduced frequency range of 0.1 Hz – 5 kHz, which, as a subordinate input, enables continuous adjustment using a 1 pps GPS signal.

Technical specifications:

- Input F1: 0.1 Hz - 150 MHz with 8 - 11 digits result; gapless measurements

0,1 Hz - 50 Hz @ 1 s:	8 digits
50 Hz - 5 kHz @ 1 s:	9 digits
>= 5 kHz @ 1 s:	10 digits
>= 5 kHz @ 10 s:	11 digits
- Auxiliary input F2: 0.1 Hz – 5 kHz with 8 digits / s; for 1 pps GPS signal
- measuring time from 0.005 - 25.000 s in 1 ms steps
- timeout from 0.010 to 25.000 s in 1 ms steps
- showing 5 - 12 digits manually or automatically depending on eff. Measuring time
- Frequency display: autom. in 'mHz' - 'GHz' or fixed format in 'MHz'
- Display formats: 1.2345 Hz; 1.2345E+0; 1,2345 Hz; 1,2345E+0
- Scaling factor for separate prescaler: 1 - 99999
- Adjustable divisor for rotation speed: 1 - 99999
- internal reference frequency (170 MHz) from local 10 MHz (VC)TCXO or ext. Reference signal 4 - 20 MHz
- automatic detection of the external or (VC)TCXO clock in 1 MHz grid
- manual or automatic comparison with 1 pps GPS signal
- Adjustment range +/- 5 ppm with 0.01 ppb resolution
- Storage of all parameters / adjustment values in the EEPROM / FRAM
- 2 x LED outputs for "Ready" and "GPS active"
- 3 x inputs for control buttons (configuration)
- Display with LCD module 2 x 16 -> 4 x 20 with presetting 16 characters / line
- RS232 connection with 9600 Bd ... 256 kBd for data output
- 5 V supply approx. 100 mA, (without LCD)

Measurement procedure:

All measurements are carried out with a reciprocal measuring method. This means that the start and end of each measurement are synchronized with the input signal. Since the end time is also the start time of the new measurement, there is no gap between the measurements. Counters running freely: there is no gate, no 'start' nor 'stop' and 'no gate time' but an minimum measurement interval. So with a 1 Hz signal, a new measured value with full resolution / accuracy is delivered every second. At higher input frequencies, all individual intervals are recorded up to 200 kHz, thus significantly increasing the resolution of the measurement results.

Resolution:

The meter readings for the input pulses are always integer and therefore exact, given by the measurement process.

In order to obtain the required high resolution, the time measurement must offer a high resolution or in other words high counter readings must be achieved in the time measurement. In order to ensure this, a minimum measuring time interval is specified, which only allows an evaluation when this time is expired or exceeded. The measuring channel F1 triggers the time measurement with about 6 ns. Therefore F1 or F2 can resolve the measured values in one second with 8 digits/s. The local 10 MHz (VC)TCXO is sufficient for at best 7 digit resolution/s. In order to obtain a correspondingly high accuracy for F1, a highly accurate ext. Reference frequency better than 0.1 ppb should be used.

Adjustment:

Input F2 can be set so that an external, long-term stable 1 Hz signal can precisely determine and correct the existing reference frequency. Many GPS receivers deliver this signal as a 1 pps signal, but it has an annoying jitter of a few 10 ns. In order for it to be used for correction, it must be averaged over a longer period of time. If you choose a time of 10 minutes (600 s), this jitter is sufficiently suppressed. If a sufficiently short-term stable OCXO is used as the reference clock, this GPS stabilization can achieve accuracies of 10 digits. Even the locally available (VC)TCXO can be stabilised to improve accuracy to 8 digits.

A sensible adjustment should be carried out to 0.01 ppb, a value that would allow 11 digits accuracy. For an adjustment range of +/- 5 ppm, you need correction values in the range +/- 500000. With comparison using a 1 pps GPS signal, a relatively quick and very precise comparison is achieved.

When comparing with 1 pps GPS-signal, the first five pulses are rejected. Then the moving average of the 1 pps signal is calculated and the reference frequency is corrected and the correction value is saved in the EEPROM only after the integration time has elapsed (typically 10 minutes). A new correction value is then determined every second and used immediately. The saved correction value (EEPROM) is updated every time the set integration time has elapsed again.

Time-out:

Since the measurements are synchronized with the input signal, a missing input signal would implicate that the measurement is never finished. The previous reading would continue to be displayed, even if it is an hour old.

In order to avoid this, a timeout value is selected in addition to the minimum measurement time, which aborts an incomplete measurement and shows it in the display with the message "no signal".

Number of digits:

Depending on the signal source, the input frequencies are very stable (OCXO) or can fluctuate considerably (RC oscillator). It can therefore be useful not always to display the maximum number of digits that can be reached, but rather to display the measured value rounded to a few meaningful digits. Alternatively, a higher number of digits can be set in order to improve the resolution of the last digit, especially in the case of results with a leading '1 ...'. Internal calculations are done with ≥ 15 valid digits.

Scaling:

For higher input frequencies, input F1 can be operated with a prescaler. A factor for the correct conversion can be set for the appropriate scaling and switched on if necessary. A divisor can also be set for rotation speed measurement, which divides the measured value appropriately if the sensor supplies more than 1 pulse / revolution.

the circuit diagram:

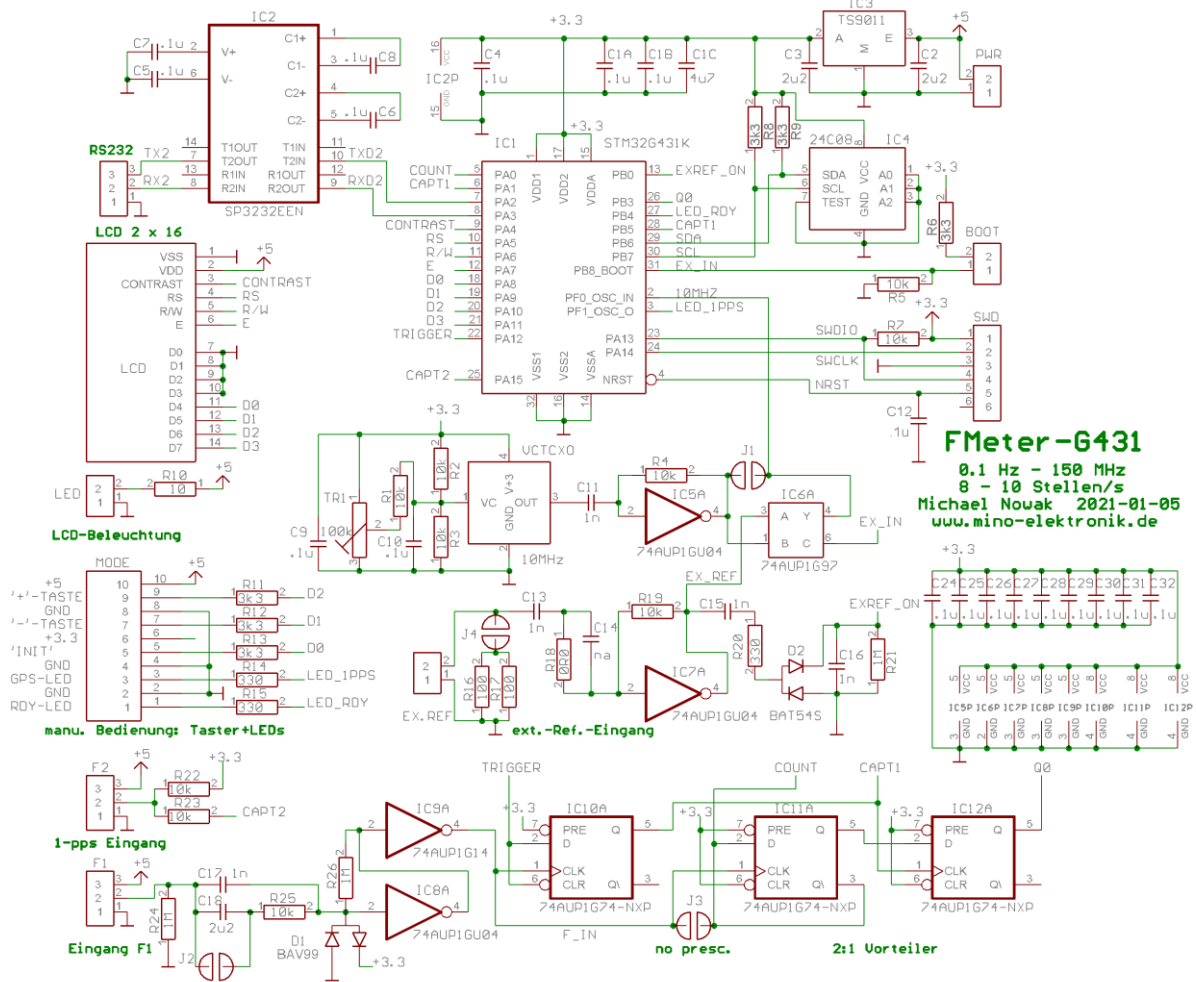

Entrance F1: (main channel)

In the basic circuit, the input stage is AC-coupled, the lower frequency being determined by C18 and R26. At higher frequencies, C17 compensates the input capacitance of the IC8 working as a linear amplifier. The Schmitt trigger IC9 provides step edges as required by the following D-FF IC10. This circuit is suitable for sinusoidal and square signals; the circuit should be adapted accordingly for external prescaler or comparator .

To supply ext. Signal conditioning (especially prescaler) are brought out at the +5 V input socket.

Frequency, period and rotation speed can be displayed as results for F1.

If a prescaler is used, the measured value can be scaled with a switchable factor. When converting for RPM, $F1 * 60$ is automatically scaled, whereby an additional divisor can be set if more than one pulse / revolution has to be taken into account.

Entrance F2: (sub channel)

This input only uses an internal counter for time measurement; the input pulses themselves are counted by software. Therefore the measuring range is limited to ≤ 5 kHz. A 1 pps signal from a GPS receiver is typically connected here for automatic adjustment of the local reference frequency. In addition to a pull-up resistor R22 and a protective resistor R23, no signal conditioning is provided.

To supply ext. Signal conditioning (especially GPS receivers with an active antenna) are brought out to the +5 V input socket.

Reference input :

In addition to the local clock generator (10 MHz (VC)TCXO), the stability of which is sufficient for a maximum of 7-8 digit accuracy, an external 10 MHz signal with high accuracy can also be used for the measurements. This is the only way to achieve a 10-digit accuracy in the measurement.

The reference input accepts sinusoidal signals with 1 V_{ss}, which are suitably processed. Switching between local clock and ext. Reference takes place automatically, whereby the ext. Reference takes precedence.

The resistors R 16 || R 17 can be activated as a 50 Ohm terminating resistor with a solder bridge. The next inverter IC7 is protected from slight overvoltage with R18 and serves as a signal shaper.

In order to allow a simple change between the internal and external reference frequency, there are separate settings for the adjustment and integration time for the GPS adjustment for both clock sources.

LC display:

An LCD module based on HD44780 with 2 x 16 to 4 x 20 digits can be used to display the measured values. Default setting: 16 characters / line.

The results of F1 are always displayed in lines 1 and 2, those of F2 in lines 3 and 4. If the results of F2 are not needed, a two-line display is sufficient. The LCD signals are on a single row 16 pin. Pin header led out, as is usual for these displays (see circuit diagram). The power supply for the background lighting is on pins 15 and 16, which correspond to the "LED" connector (see circuit diagram). The series resistor R10 (10 Ohm, type 1206) may have to be adapted to the LCD module used.

ser. Data output RS232:

A result can be output via RS232 for automatic further processing of the measured values. The options are: no output, frequency, period and RPM of F1 and frequency of F2. Default setting: frequency F1

In addition, various parameters can be set via RS232, provided that manual operation is not intended or the settings are to be made remotely.

+5 V power supply:

The +5 V are used directly to supply the LC display and ext. connected electronics. The local supply voltage is +3.3 V, which is supplied by a linear voltage regulator. The local reference frequency depends on the stability. Too high ext. Current consumption (> 50 mA) and pulsed current load are therefore not permitted.

Storage of the measurement parameters:

All setting and adjustment values are saved in an EEPROM and used when switching on. With its typical 1×10^6 write cycles, it is sufficient for most applications.

If you choose a permanent comparison via 1 pps GPS signal with 10 minutes integration time, the max. Write cycles with uninterrupted operation are sufficient for around 19 years. A FRAM module can be used as a substitute for shorter write intervals. Memory modules with a capacity of 256 bytes are sufficient.

Connections on the circuit board:

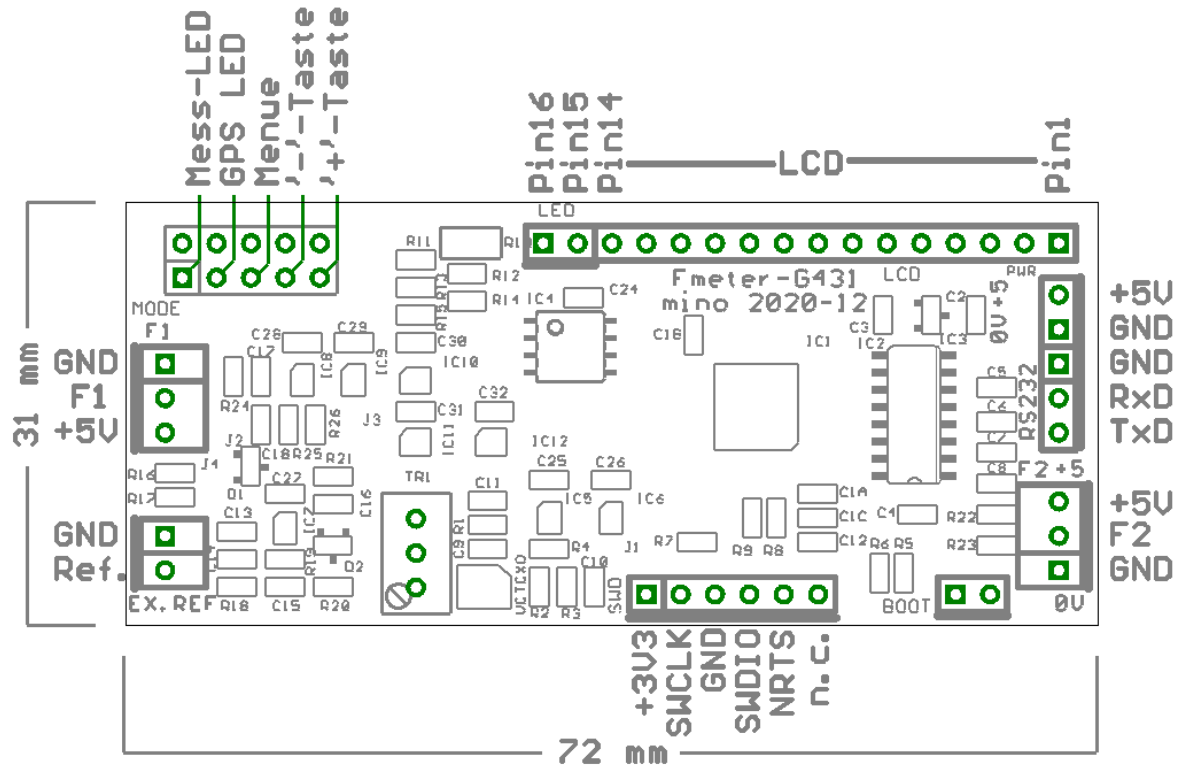

assembled demo-board:

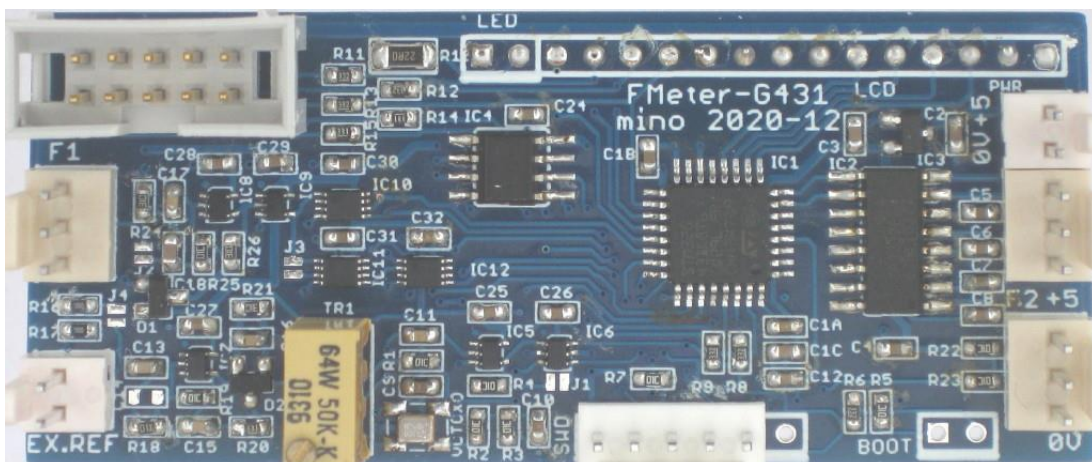

manual operation:

The following instructions do not describe an existing device of which the front panel could be shown as a photo, which could make the operation understandable. A bit of concentration and imagination is therefore necessary so that the meaning and purpose of the operation can be understood.

A total of three control buttons are required, the left one labeled with "-", the right one labeled "+" and the middle one labeled "Menu" or "Setup"/"Mode"/"Init".

"+" and "-" both have a repeat function and are essentially used to increase or decrease a value. "Menu" calls up a menu item, switches to the next or cancels the menu with a long button press, but the last change is still applied.

To cancel without changing the settings, press "+" and "-" at the same time.

The two upper lines of the LC display are required for the settings menu, but the measurements on F1 and F2 continue to run in the background during the settings. The effects of the changes can thus be followed directly, if necessary with measured value output via serial interface.

The last menu item called up is memorized during operation. Briefly pressing the "Menu" button twice calls up the last selected menu item so that the setting can be repeated there directly. A long press of the "Menu" button saves the change and returns to the measured value display of F1.

Wiring LEDs

The connector "Mode" (see circuit diagram: 10-pin header) offers, in addition to its supply pins "GND", "+ 3V" and "+ 5V", the direct connection of 2 x LEDs and 3 x buttons. Button and LED signals refer to GND (0 V).

One LED has the function of indicating a completed measurement by lighting up; the other LED shows the status of the alignment based on a 1 pps GPS signal. While the "Ready LED" (Mess-LED on pin 1 of Mode) lights up for an adjustable time, the GPS LED (on pin 3 of J1) flashes according to the progress of the adjustment: first briefly and then longer and longer until the LED stays on constantly.

Wiring button

The buttons for the operating menu are implemented with three buttons:

1. Button (on pin 9 of Mode): "+" with repeat function
2. Button (on pin 7 of Mode): "-" with repeat function
3. Button (on pin 5 of Mode): "Menu / continue" (short) and "Abort" (long press)

Button 1 and button 2 ("+" and "-") simultaneously: abort the operating menu without saving the last setting. The buttons switch the relevant inputs to GND (0 V).

Basic status of the display:

After switching on, the values as they were last set are displayed on the LCD. If the LCD shows four lines, lines 3 and 4 **always show** the frequency from input F2. For lines 1 and 2, the display can be set to F 1: frequency + period, only frequency, only period, only RPM.

Additional functions V1.6 are:

mean value + count "Fmean: n=", Fmax+Fmin, standard deviation + count "S-dev: n="

With the "+" key the selection is shifted to the "S-dev" and with the "-" key to the frequency+period display. Pressing "+" and "-" keys simultaneously clears actual shown statistic.

The settings menu is called up with button 3 "Menu" and switches through the following menu items one after the other:

"Settings input F1" and "General settings",

where again the "+" button switches to the last menu item and the "-" button switches to the 1st menu item. Another short tap on "Menu" then calls up this menu item.

Menu item "Settings input F1"

The following values can be changed:

<i>F1 measuring time:</i>	5 ms – 25.000 s; Default value = 1.000 s
<i>F1 timeout:</i>	10 ms – 25.000 s; Default value = 5.000 s
<i>F1 digits displayed:</i>	5 - 12 digits or "automatically", default value = 10
<i>F1 prescaler:</i>	"off", "active"; Default value = "off"
<i>F1 prescaler factor:</i>	1 - 99999, if prescaler = "active"; default value = 1
<i>F1 RPM divisor:</i>	1 - 99999; default value = 1

menu item "General settings"

The following settings can be made here:

<i>ser. Data output:</i>	no output, F1 frequency, F1 period, F1 speed, F2 frequency Default value = F1 frequency
<i>Ready-LED switch-on time:</i>	1 ms – 10.000 s; Default value 0.100 s (retriggerable)
<i>ser. Baud rate:</i>	9k6, 19k2, 38k4, 57k6, 115k2 (default value), 230k4, 256 k;
<i>GPS alignment:</i>	"off", "active"; default value = "off"
<i>GPS sync. time int. clock:</i>	10 - 1800 s; default value 100 s
<i>GPS sync. time ext. clock:</i>	10 - 1800 s; default value 600 s
<i>manu. adjustment int. clock:</i>	-500000 -> +500000; autom. adjustment with GPS alignment
<i>manu. adjustment ext. clock:</i>	-500000 -> +500000; autom. adjustment with GPS alignment
<i>LCD line length:</i>	16 or 20; default value = 16
<i>LCD contrast:</i>	0 - 100; default value = 20
<i>Display format:</i>	1.2345 Hz; 1.2345E+0; 1,2345 Hz; 1,2345E+0
<i>Frequency display:</i>	autom. in 'mHz' - 'GHz' or fixed format in 'MHz'

An example to get from the measuring mode of F1 into the menu "General Settings":

briefly press the "Menu" button once to call up the settings

press the "+" button once until "General settings" is displayed

briefly press the "Menu" button once to call up the 1st menu item of the general settings.

Control via RS232:

Not only are measured values output via the serial interface, but parameters for the measurement are also entered and permanently stored in the EEPROM. The data format is 8N1 with a baud rate of typically 115.2 kBd. Each command sequence is preceded by the character '.' initiated; this is optionally followed by a decimal number (nnn) in the range 0 - 999999 (or -500000 to 500000 for frequency correction). The command sequence ends with the actual command (capital letter or character).

The set values can be queried by simply entering a '.' and the command will be sent. The command and the set numerical value are output as a response.

Instead of the '.' an <ESC> character can also be used.

The following commands are recognized, although no distinction is currently made between uppercase and lowercase letters; unknown commands or incorrect numerical values are ignored. (Inserted spaces are for readability only and are not sent):

.nnn A	Minimum measuring time F1, nnn range 5 - 25000 in 1 ms steps Example '.4000A' sets the meas. time for input F1 to 4000 ms (4 s).
.nnn B	As with 'A' but measuring time for input F2
.nnn C	Timeout F1, nnn range 10 - 25000 in 1 ms steps Example '.10000C' sets the timeout for input F1 to 10000 ms (10 s).
.nnn D	As with 'C' but timeout for input F2
.nn E	Number of displayed digits input F1 from 5 - 12. If n = 0 is entered, the digits are dependent on the eff. measuring time determined automatically
.nn F	Number of digits displayed for input F2 as for input F1. If n = 0 is entered, the digits are dependent on the eff. measuring time determined automatically: > = 1 s measuring time -> 8 digits
.n G	Prescaler active for F1: 1 = with prescaler as set, 0 = no scaling
.nnn I	Prescaler factor for F1; Range 1 - 99999
.nnn K	Contrast voltage for the LCD adjustable in the range 0 - 100; relative value depending on the display used
.nnn L	The 'Ready' LED lights up, range 1 - 10000 in 1 ms steps, can be retriggered
.nnn O	Offset value for correcting the currently used reference frequency (internal or external) in 0.01 ppb steps, adjustment range -500000 to 500000 corresponds to +/- 5 ppm of the clock frequency. This value is initially only temporarily stored in the RAM. Control query of the set value with: '.O'

"nnn" is a relative value that is added to the existing offset.
 With '.00' the set value is set absolutely to 0.
 If an ext. GPS signal is used for adjustment, the manual offset has no effect and is used by the autom. adjustment overwritten.

- .nnn P Divisor for scaling the speed at F1; Range 1 - 99999
- .n R Selection of the output value via RS232 interface;
 Values for n: 0 = no output,
 1 = frequency F1, 2 = period F1, 3 = speed F1, 4 = frequency F2
- .n S **especially for F2:** 1 = GPS adjustment possible via 1 pps signal;
 0 = switched off.
- .nnn T Time in seconds for averaging the GPS signal at **an internal** reference frequency with typ. 100 s; Setting range: 10 - 1800 seconds
- .nnn U Time in seconds for averaging the GPS signal at **an external** reference frequency with typ. 600 s; Setting range: 10 - 1800 seconds
- .V Version request, issue 'FMETER- G431 V1.0'
- .nn W Line width of the LC display: 16 or 20
- .n Y Display format for measured values
 0: 1.23456789 Hz 1: 1.23456789E+0
 2: 1,23456789 Hz 3: 1,23456789E+0
- . * Output of the character '*' as an echo for synchronization (time stamp)
- . <Ctrl + S> This sequence writes the set frequency offset permanently into the internal EEPROM so that it is used automatically the next time the device is switched on.
 The autom. comparison via GPS has higher priority and overwrites the manual setting!
- Version 1.6:**
- .# request of statistical values:
 count, mean value, F1-maximum, F1-minimum, standard deviation
 A leading '+' sign indicates statistical values.
- .0# Reset all statistical values
- .1# send "count"
- .2# send "Fmean"
- .3# send "Fmax"
- .4# send "Fmin"
- .5# send "S-dev"

3. by manually specifying an absolute correction value via ext. control button
4. Use of a highly precise, highly stable reference clock
5. If equipped, the VCTCXO can be pulled to the setpoint frequency using the multi-turn trimming potentiometer.

During the comparison, separate correction values for the internal and external clock are determined, used and also saved. You should wait for the reference clock to warm up before performing an adjustment.

Regarding 1.) The automatic comparison with GPS signal is the recommended method, which is why it is described first. For this it is necessary to apply an exact 1 Hz signal to input F2 and to use the autom. switch on alignment via GPS ("active" manually via button or via RS232 command). The adjustment is only carried out if the 1 Hz signal and the active reference clock differ by less than +/- 5 ppm. Otherwise the frequency at F2 is only measured and displayed. A single exposure of the 1 Hz signal breaks the autom. adjustment and starts it again if a stable signal is present.

The 1 Hz signal from a GPS receiver can fluctuate slightly at the beginning. Therefore the first five pulses are ignored. Then, from the impulses arriving at F2, the sliding mean value over the period (GPS adjustment time) is calculated as set for the internal or external clock frequency. As long as the ring buffer for the moving average is not yet full, the GPS LED (if connected) flashes in such a way that, based on a small pulse duty factor at the beginning and an increasing pulse duty factor, the further the averaging progresses, the LED remains switched on continuously as soon as the first complete valid mean value is available. At this point in time, the correction value is calculated for the first time, used and also written to the EEPROM / FRAM. The automatic adjustment is finished at this point. The next time the device is switched on, this correction value is restored even if no GPS signal is available.

However, it is a great advantage to leave the GPS signal connected. As a result, a new mean value and a new correction value are determined every second. Slow changes in the reference clock rate (due to drift, heating) are thus continuously compensated. The correction value is always written to the EEPROM / FRAM after the set integration time has elapsed.

The integration time can be specified separately for the internal and external clock. Depending on the short-term stability of the reference clock, it is important to find a good compromise that enables the highest possible accuracy with the shortest possible response time.

Assume that the GPS signal has a typical jitter of 30 ns. In order to reduce this clock inaccuracy to ≤ 100 ps, as it is necessary to achieve a 10-digit accuracy is required, averaging over ≥ 300 s is required. That would be the minimum reasonable integration time for max. accuracy. In practice, it is advisable to double this time to 600 s (corresponding to 10 minutes = default value). The short-term stability of the reference clock should therefore be better than 0.1 ppb / 10 minutes so that it can be regulated.

If the internal (VC)TCXO is used, this short-term stability cannot be achieved under any circumstances. A slight warming of the circuit board, a short draft are enough to change the output frequency significantly. If you limit yourself to 8-digit accuracy, the time measurement must be accurate to ≤ 10 ns for one measurement / s. For a GPS signal with 30 ns jitter, an integration time of 10 s would be completely sufficient. The advantage of this short time is that frequency changes of the (VC)TCXO can be readjusted very quickly. The default value for the internal clock is set to 100 s in the frequency counter, which enables a 9-digit resolution, even if the accuracy cannot be fully achieved.

It is - as said - a compromise depending on application in the range 10 s - 1800 s may be adjusted.

Regarding 2.) The adjustment via RS232 command is a bit more time-consuming and only ever provides a fixed value for frequency correction. Furthermore, an exactly known frequency must be applied to F1, on the basis of which the adjustment can be carried out. Frequencies of 10 MHz, 1 kHz or 1 Hz are preferably suitable. The LC display should be set so that the frequency and period of F1 are displayed simultaneously. Under certain circumstances you can manually increase the displayed digits to 11 in order to achieve a better resolution.

With an F1 frequency of 10 MHz, the goal is to get 10.00000000 MHz and 100.0000000 ns simultaneously displayed results. A change of 0.1 ppb is immediately visible when one of the values jumps to '9' in all places.

As with automatic GPS alignment, the internal and external reference frequencies are aligned separately. The comparison relates to the selected source (internal / external). It makes sense to choose a measurement time ≥ 1 s as long as possible for the adjustment.

So that the last digit can still be fine-tuned in a 10-digit measurement, the gradation of the associated offset is 0.01 ppb (1×10^{-11}). A frequency displayed that is too low is corrected with a positive offset (.nnnnO) and a frequency that is too high with a negative offset (-.nnnnO). The entered offset is added to the current correction value. If necessary, this must be reset to '0' at the beginning of the comparison with '.00' or displayed with the query '.O'.

Example: the input signal at F1 is exactly 10.00000000 MHz and an OCXO serves as an external reference clock. The displayed value is 9.99999989 MHz. You can see that the displayed value is ___11 too low. In the 10-digit display, the last digit provides a resolution of 0.1 ppb. Since the correction value (offset) has a higher resolution of 10, it must be entered with 110. Input: '.1100'

Then the displayed value must be checked again and corrected if necessary, which can be done with small steps of, for example 5: '.50' to increase or '-.50' to decrease the offset. As said before, the alignment is perfect when "10.00000000 MHz" and "100.0000000 ns" are displayed at the same time.

For the first time, the settings are only temporarily stored in the RAM, so that the last setting is not initially 'destroyed'. You can therefore also carry out the comparison empirically without having set anything wrong.

In order to be able to use the new setting again the next time the device is switched on, the new correction value must be written into the EEPROM / FRAM after the calibration has been completed with '. <Ctrl-S>'.

to 3.) The manual setting of the correction values needs an exactly known ext. input frequency at F1, but otherwise works without a GPS signal or RS232 terminal. This makes operation a little more time-consuming.

Again the LC display should show the frequency and period of F1 in the first two lines. As described above, three buttons for 'Menu', '+' and '-' must be connected with which the settings are made.

Since the setting menu requires the first two lines of the display, the correction value must be set and the measured value checked alternately.

A frequency of 10.00000000 MHz applied to F1 is measured. If the frequency or period displays are not displayed with sufficient accuracy, the 'General settings' menu item is called up using the control buttons. Further keystrokes on 'Menu' lead to the items' manu. internal adjustment: xxxx 'or' manu. external adjustment: xxxx '. 'xxxx' shows the currently set, absolute correction value. The value that corresponds to the reference clock source used must now be selected.

The correction value is increased or decreased with the '+' or '-' buttons, with the changes being made in increasing steps if the button is pressed for a longer period of time. The new correction value can either be calculated or initially only roughly estimated and then set. The setting is completed by pressing 'Menu' for a long time, which on the one hand saves the new correction value but also shows the measured values for F1 in the display again. As long as the adjustment is not satisfactory, pressing 'menu' twice takes you back to the last setting of the correction value and you can change it again. A long key press on 'Menu' returns to the frequency display with the new correction value.

to 4.) When using a highly precise, highly stable reference clock, no adjustment is necessary. All you have to do is check that the correction value is set to '0', which can be done either by means of the operating button or the RS232 command.

to 5.) manual setting with trim potentiometer

If a VCTCXO and a trimming potentiometer are fitted, this is the simplest type of adjustment without further additions. A known frequency is applied to F1 and the potentiometer is turned so that the correct value is displayed.